

## Belt Tensioning

A critical portion of the assembly process when using belt drives is setting the appropriate belt tension for the application. Varying belt tensions can cause unit-to-unit tuning to vary. Excessive belt tension may cause premature wear of the belt and the bearings, and may even break the motor or load shaft.

**CAUTION:** DO NOT squeeze the belt to check tension! This seems so natural, and simple, but it can bend shafts, and damage bearings! In the diagram shown below Theta is 5 degrees. The force placed on each motor shaft is the squeeze force (each side, vertical arrows) divided by the tangent of the angle. That is

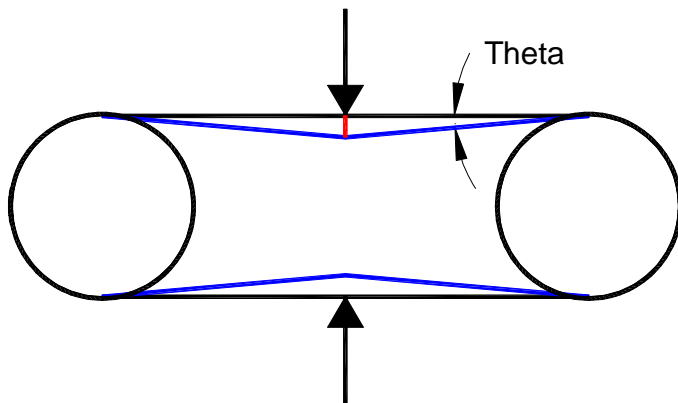

$$F_{\text{shaft}} = F_{\text{perp}} / \tan(\text{Theta})$$

For a 5 pound squeeze and a 5 degree angle, this is applying about 57 pounds of lateral force to each shaft. (Note: the force on each belt side is half this, but there are two sides).

A lighter squeeze of 1 pound that only deflects the belt by 1 degree would also produce a force of about 57 pounds on each shaft!

A much better way to SET belt tension is by use of a sliding nut bracket that has an extension to attach a spring weight gauge – such as a fish scale. Holding the scale to produce the wanted belt tension, the screws nearest the belt are tightened first to bring the shaft perpendicular to the surface while the base can still slide. The remaining screws are then tightened. This produces a uniform belt tension unit-to-unit, and person-to-person, which helps with both reliability and repeatability. This style of fish scale can be found on line for as low as ~\$13 for a digital unit in .01 lb increments.

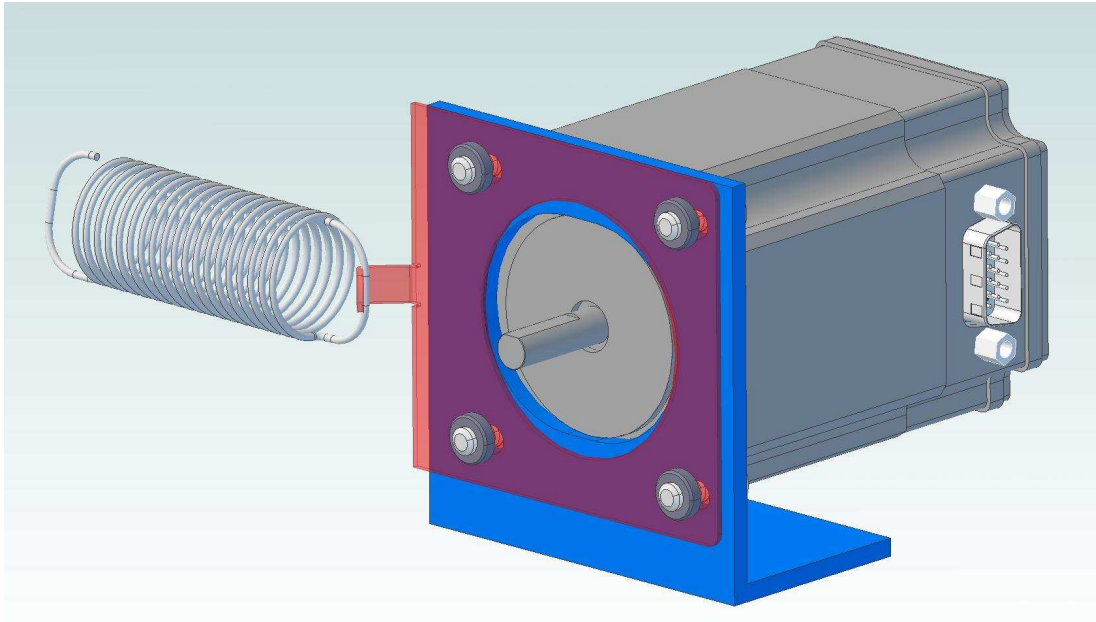

The drawing above shows the tensioning plate as semi-transparent only to allow the mounting plate behind it to be seen. This would normally be made of metal. The fish scale is shown as a spring; it is only present while setting the belt tension. After tightening the screws, the spring/scale is removed. A PDF version of this drawing is included which can be rotated for further information.