

SilverNugget N2 Driver Enable

Overview

This document describes the Driver Enable option available on the SilverNugget N2 Controller options E5, E7, M5, M7, F7. See price list for part number details.

The Driver Enable option allows the drive circuit to be hardware disabled via input #3. This provides a hardware safety option that allows the entire driver circuit to be disabled while the control electronics remain active. Current position information as well as any other user information is maintained.

Driver Enable line is pin 4 (I/O #3) of the SilverLode Multi-Function Interface (SMI) port. The Driver Enable option disables I/O #3 as a standard I/O line. Attempting to use it with command such as Set Output Bit (SOB) will cause an execution error that halts the program. NOTE: I/O #3 can still be used in the Kill Motor Condition command (KMC) as described latter in this document.

Hardware

The Driver Enable line is pulled low (to logic ground) with a 4.7kΩ resistor. Therefore, the line is normally low and active high. It must be tied to +5 volts to allow the driver to operate. There is a +5 VDC output from controller that can be used for this purpose. Applying higher voltages (such as driver or line power) will damage the input circuitry.

SMI Port on Controller

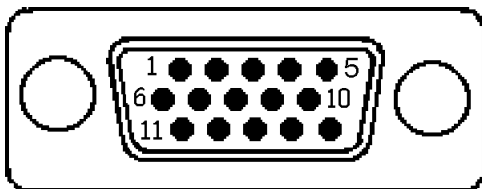

NOTES: I/O lines 1 & 2 each have internal 4.7kΩ pull-up resistors connected to the internal +5 VDC-100 mA power supply.

I/O line 3 is internally connected to a 4.7kΩ resistor to ground. It is enabled when connected to a +5 VDC supply.

SMI Port

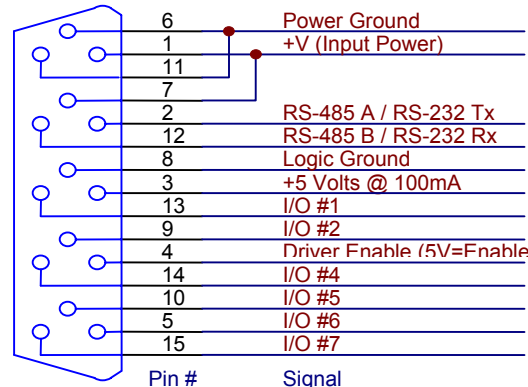

Factory Default Initialization – N2 Driver Enable.qcp

This customized initialization file is designed for use with the driver enable option and is provided with QuickControl®.

Driver Enable Initialization File:

Folder: "...\QuickControl\QCI Initialization\"

File: "Factory Default Initialization – N2 Driver Enable.qcp"

If the drive is not enabled (input low), the servo cannot move which prevents initialization, including encoder alignment motion and program execution. This file checks for Driver Enable before trying to move. If the drive is not enabled, the initialization program will slowly flash the green LED. Restoring the enable line will allow the servo to initialize and function normally. The check for driver enable is done by the first KMC command. See Factory Default Initialization – N2 Driver Enable.qcp for details.

The second modification is to the KMC command at the end of the program. The standard file only has Over Temperature enabled, while the drive enable program also enables I/O #3 (Low).

If I/O #3: Low is not specified as a kill condition, physically disabling the driver enable line will disable the driver, but not affect program flow. This means that any application running will continue to execute. The program will even execute motion commands, although the motion will not actually occur. If the servo has been attempting moves while disabled, significant position error may develop. When the drive is enabled, the servo will

immediately try to make up this error. If special care is not taken, the error will result in unpredictable and extremely rapid motion.

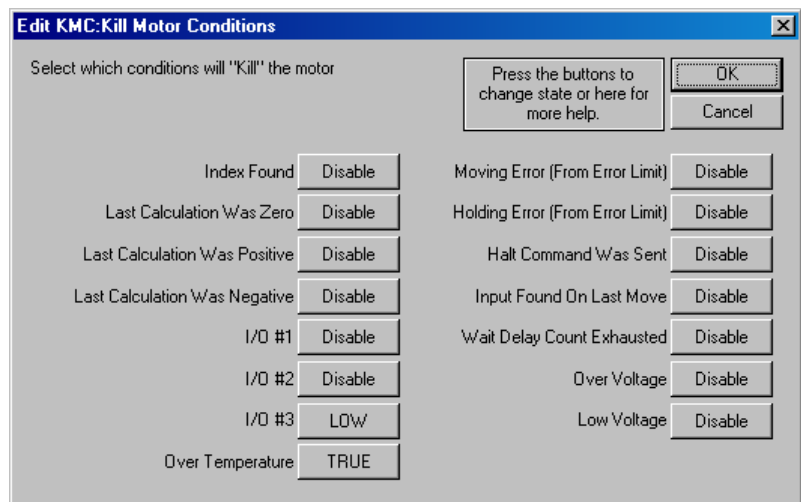

Driver Enable Option And Other Commands

Enable Encoder Monitor (EEM)

No index on I/O #3.

Select External Encoder (SEE)

Only I/O Lines #4 and #5 may be used.

Configure/Set/Clear I/O (CIO, SOB, COB)

Use of I/O #3 will cause program error.