

SilverDust D2-IGK Datasheet

Servo controller/driver for QuickSilver's NEMA 11, 17 and 23 frame, high torque, direct drive servomotors. This SilverDust features a simple, compact design to save cabinet space and cost. It also features CANopen®.



QCI-D2-IGK

System Overview

Point-to-Point Moves

- Relative or Absolute
- Velocity or Time Based
- S-Curve

Advanced Motion Profile Moves

- Profile Move Commands
- Register Based
 - Position/Accel/Decel/Vel
 - Modify On-the-Fly

Multi-Axis Linear Interpolation

- XYZ Coords Contained in Text File
- CANopen® used for local bus
- 1000+ Points Stored In NV Memory

Built-In Voltage Clamp

- Regenerative Braking Resistor

Input/Output

- 7 TTL Digital I/O
 - Use for QCI-BO-B52 24V I/O
- 4 Analog Inputs (Joystick)
- Analog Output Option
- Programmable Limit Switch (PLS)
 - Dynamically Sets Output Dependent on Motor Position
- Secondary Encoder In

Program and Data Storage

- 32K Non-Volatile Memory:
- 2000-3000 Program Lines
- User Data Examples
 - CAM Tables
 - Motion Profiles
 - Lookup Tables

Electronic Slip Clutch/Brake

- Variable Torque
- Wind/Unwind Applications

Anti-Hunt™

- Optionally use Open Loop While Holding
- No Servo Dither While At Rest

Electronic Gearing/Camming

- Follow Encoder (A/B Quadrature) or Step and Direction
- Dynamic Gear Ratios
 - Integer Ratios 32767:1 to 1:32767
 - Decimal Ratios to 7 Places
- Electronic Cam
 - Import Tables From Text File
 - Over 2500 Points
 - Multiple Tables

Communications

- RS-485/RS-232 @ 230K Baud
- ASCII,Binary,Modbus®,DMX512
- Host Control While Servo in Motion
- CANopen®, CiA® DSP 402

Programming Language

- Easy, Menu Driven Interface
- Command Parameter Prompts
- No Syntax Errors
- User Namable I/O and Registers

Advance PVIA™ Servo Loop

- 100:1 Inertial Mismatch
- Direct Drive Oversized Inertial Loads
 - Flywheels/Belt Drives
 - Typically Without Gearheads
- More Stable Than PID

Digital 4 Quadrant Vector Drive

- DSP Driven for Reduced Noise

Multi-Task/Multi-Thread

Compatible with QCI Motor/Encoders

- NEMA 11 Frame
 - 4000 Counts/Rev Encoder
 - Up To 9 oz-in (continuous)
- NEMA 17 Frame
 - 8000 Counts/Rev Encoder
 - Up To 43 oz-in (continuous)
 - IP50 or IP65
- NEMA 23 Frame
 - 8000 Counts/Rev Encoder
 - Up To 300 oz-in (continuous)
 - IP50 or IP65

UL, CUL, CE

Electrical Specifications

Input Power

Voltage

+12 VDC to +48 VDC, regulated. The controller must be initialized for the actual operating voltage using Initialization Wizard.

Over-Voltage Protection

Voltages exceeding +55 VDC will permanently damage the controller/driver electronics. The controller includes an onboard clamp circuit.

Reverse Polarity Protection

Reverse polarity protection is provided. Note, however, if the power supply is not floating, connecting the V+ input to Ground will cause this potential to be present at the communications and I/O lines, which may damage these lines or that to which they are connected.

Input Current

4 Amps maximum for any input voltage, +12 VDC to +48 VDC.

Output Power

Output/Driver Current

3.5 Amps continuous per phase *; 4.5 Amps peak per phase *.

* With Adequate Heat Sinking / air flow.

Maximum Output Power

150 Watts continuous power with adequate heat dissipation.

Encoder Interface

Quadrature differential signals from motor encoder.

External (secondary) encoder can be used for dual loop operation or for encoder following (Quadrature).

Inputs & Outputs

Standard I/O

IO1-IO7

Digital Inputs

0 to +3.3 VDC. LVTTTL level compatible.
Effective internal 200K ohm impedance to +3.3 V.

Digital Output Voltage

0 / +3.3 VDC.

Digital Output Current

Sinking or Sourcing
I/O 1, 4, 5, 7 outputs 4 mA MAX
I/O 2 and 3 outputs 2 mA MAX
I/O 6 outputs 8 mA MAX

I/O Over-Voltage Protection

An over-voltage limiter protects each standard I/O line up to 30 volts. Applying voltages greater than 30 volts will permanently damage the digital I/O.

Analog Inputs

0 to +3.3 VDC input signal range.
10 bit ADC resolution (single).
11 bit ADC resolution (differential).
Analog inputs 1 to 4 are mapped to share digital I/O lines 4 to 7.
Each input has an effective internal 200K ohm impedance to +3.3 VDC.
Analog signals are read every servo cycle (120 μ sec.) and the converted analog data is processed through a 5 ms filter to reduce noise & transients.

Analog Output

Available on I/O 2, but requires Basic Breakout w/ Analog Out (QCI-BO-B1A). See technical document QCI-TD048.

Communications

Hardware Interfaces

RS-232, RS-232 multi-drop, RS-485 multi-drop (software selectable), CANopen®

Protocols

8-bit ASCII, 9-bit binary, or Modbus® RTU.

Hardware Configuration Settings

Available Baud Rates: 2400, 4800, 9600, 19.2k, 28.8k, 57.6k, 115.2k or 230.4k
Data Bits: 8
Stop Bits: 1.5 or 2
Parity Bit: None

Mechanical Specification

QCI-D2-IGK

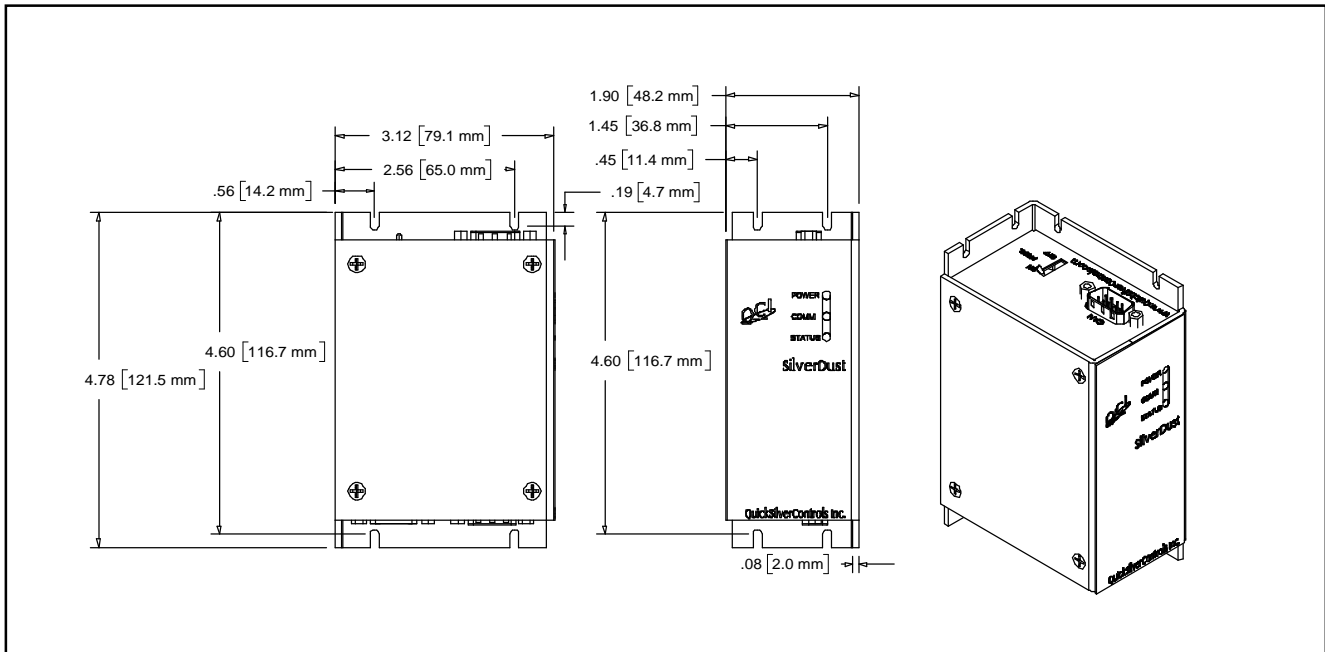

Note: See our website for 2D drawings and 3D models.

Environmental Specifications

Operational Temperature

-10 C to +80 C

Storage Temperature

- 40 C to +85 C

Humidity

Continuous specification is 95% RH non-condensing.

Shock

Limitation is approximately 50g/11ms.

IP Rating

IP20 with cables attached.

Connector Data

Front Panel (FP)

- Status LEDs

Top Panel (TP)

- (TP1) Processor Switch
- (TP2) CAN Connector

Bottom Panel (BP)

- (BP1) SMI Interface
- (BP2) Motor Interface

(TP1) Processor Switch

The Processor Switch turns on and off the power to the processor. The main power should be OFF before connecting or disconnecting the system. The Processor Switch does **NOT** disconnect main power.

(BP1) SilverLode Multi-function Interface (SMI) Port

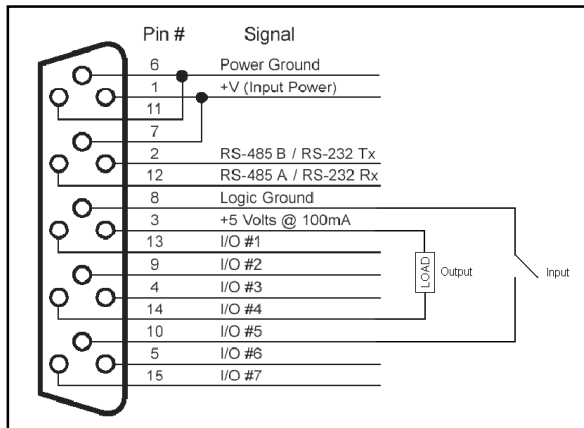

These signals provide power, communications and 3.3v IO (digital and analog).

NOTE: QCI has many modules capable of breaking out these signals. For example:

- Basic Breakouts (QCI-BO-B, QCI-BO-B1)
- Basic Breakout w/ Analog Out (QCI-BO-B1A)
- Breakout w/ 24V IO -5in 2out (QCI-BO-B52)
- 24V Optical I/O Module (QCI-OPTMC-24)*

*Requires QCI-EC-SMI cable
See technical documents on our website for details.

This port provides QuickSilver's basic Power, Communication, standard I/O for easy connectivity in large systems. The SMI port is standard on all our controllers which helps make new products backward compatible with older ones. See above sections for details on these signals.

(BP2) Motor Interface

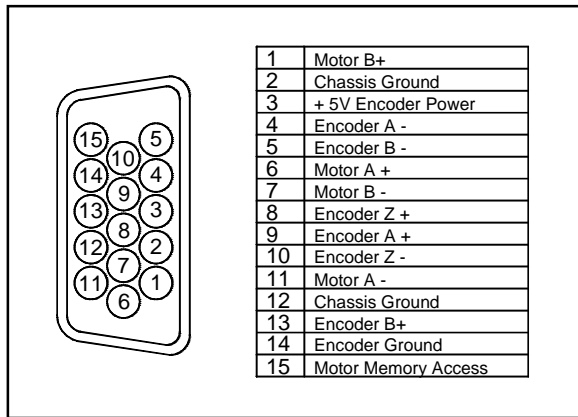

QCI recommends our QCI-C-D15P-D15S-nn (nn = length) cable to interface between the motor and the controller. Note: 01, 02, 04, and 10 foot cables are standard lengths.

The Motor I/F Breakout (QCI-BO-M1) can be used to breakout these signals. See Technical Document QCI-TD057 "Motor I/F Breakout - QCI-BO-M1,QCI-BO-M2".

(TP2) CAN Interface

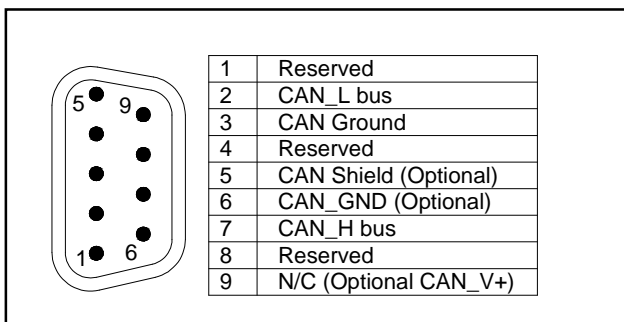

The CAN signals are available via the 9 pin male D-sub connector on the top of the unit. This connector follows the standard D9 configuration. A breakout module (QCI-BO-K) is available to break these signals out to a screw-terminal header.

The CAN bus connection is NOT isolated, but does include transceivers which have an extended +/- 80v fault protection range. The CANopen communications protocol allows the unit to function as a master, slave, or peer on a CANopen network. See the SilverLode CANopen User Manual for details on the CANopen protocol. This protocol operates simultaneously and independently from the standard serial protocols.

Note that a 120 ohm ½ W termination resistor is needed at each end of the CAN network (only two per system). This termination is not provided onboard the QCI-D2-IG-J(1) controller and must be provided by the user. The QCI-D2-IGK uses the common power/communications ground as the CAN ground. Do not connect conflicting grounds within the system. No external CAN power is require by the unit.

Recommended Components

SilverDust IGK Start-Up Kit (QCI-SKB-D2-IGK)

For first time users, QCI recommends purchasing the QCI-SKB-D2-IGK Start-Up Kit which includes:

- SilverDust D2 (QCI-D2-IGK) & Datasheet (QCI-DS023)
- QuickControl Software CD (QCI-QC)
- User Manual & Command Reference (QCI-SLM)
- Basic Breakout (QCI-BO-B)
- CAN Breakout (QCI-BO-K)
- Communication Cable (QCI-C-D9M9F-6)
- 4' DB15HD Motor I/F Cable (QCI-C-D15P-D15S-4)
- DIN Rail Bracket (QCI-DIN1)
- Start-Up Kit Setup Instructions (QCI-TD065).

With this Start-Up kit, a power supply, and a motor/encoder, you will have everything you need to get started. See technical document QCI-TD065 on our website for details.

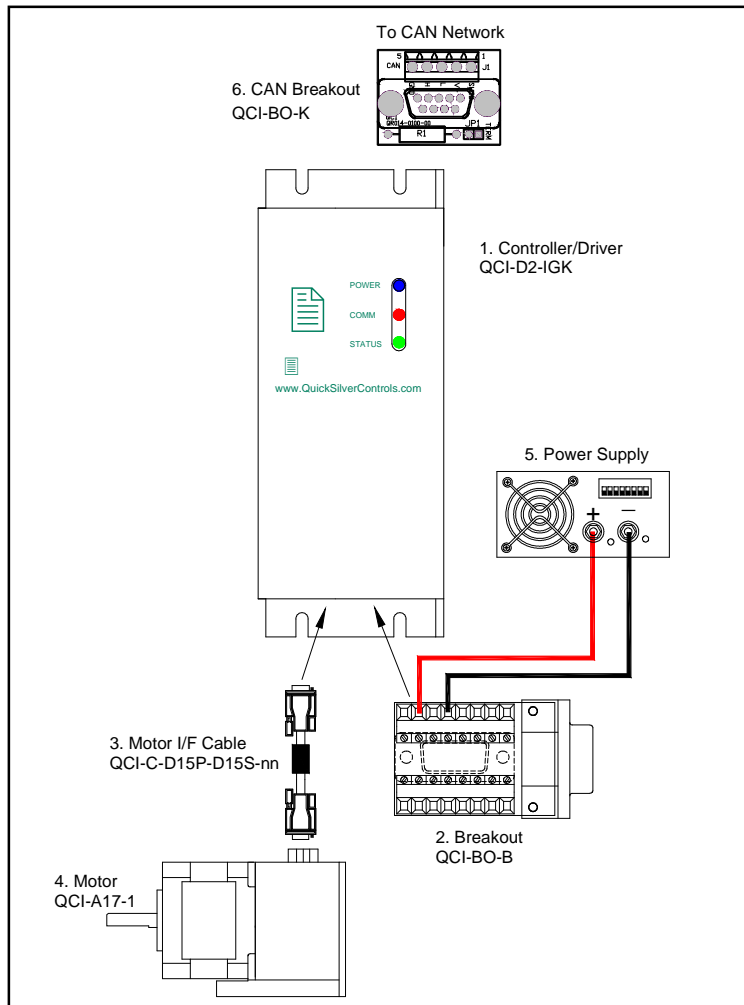

1. Controller/Driver

SilverDust D2 IGK (QCI-D2-IGK). This is an closed open frame system without extended I/O. For users that do not need the extra I/O capabilities, this system is recommended for significant cost savings. This controller includes CANopen capability.

2. Basic Breakout (QCI-BO-B or QCI-BO-B52)

QCI recommends purchasing a breakout to simplify wiring power, communications and I/O. QuickSilver offers several breakouts (see our website), but the simplest is our Basic Breakout (QCI-BO-B). To convert the 7 TTL I/O to 5 24V isolated inputs and 2 open collector outputs, select the QCI-BO-B52.

3. Motor I/F Cable

For standard system, this D-sub type cable goes between the motor and the controller. The generic part number is QCI-C-D15P-D15S-nn. Replace the last two digits “nn” with length of cable in feet (i.e. –10 for 10 feet).

For IP65 system, a special IP65 cable goes in between the motor and the controller. The motors and cables are IP65, but not the controller/driver. The generic part number is QCI-C-D15P-T14S-nn. Replace the last two digits “nn” with length of cable in feet (i.e. –10 for 10 feet).

4. Motor

The SilverDust D2 is capable of driving any A 17 or 23 I-Grade motor/encoder. See the following datasheets for more information:

QCI-DS007: NEMA 17 I-Grade Motor/Encoder

QCI-DS008: NEMA 23 I-Grade Motor/Encoder

See QCI-DS017 for details on using QuickSilver's NEMA 11 frame motor with the IG.

5. Power Supply

Power supply selection is motor dependent, but the following will work with all the 17 and 23 frame motors.

S-210-48 (48V, 4.4A, 210 Watt)

6. CAN Breakout (QCI-BO-K)

The CAN breakout brings the CAN connections out to screw terminals and provides an optional termination point for the CAN network. See Technical Document (QCI-TD064).

CANopen® and CiA® are registered community trade marks of CAN in Automation e.V.

Part Number

SilverDust™ IGK Controller/Drivers		
DRIVER	CONTROLLER	OPTIONS
<p>QCI-D2 - 3.5 Amp</p> <ul style="list-style-type: none"> • For 23 Frame and Smaller • 3.5 Amps per Phase Continuous* • 4.5 Amp Peak • Input Power: 4A@12V-48V <p>* Depending on heat sink (25C ambient).</p>	<p>IGK – SilverDust D2 IGK</p> <ul style="list-style-type: none"> • 7 TTL Inputs or Outputs (use QCI-BO-B52 for 24V I/O) • 4 Analog Inputs (Joystick) • Analog Output Option (use QCI-BO-B1A) • RS-232 or RS-485 • ASCII, Binary, Modbus®, CANopen • Voltage Clamp And Resistor • DB15HD (pin): SMI Port • DB15HD (socket): Motor I/F including motor power and encoder • CANopen® 	<p>Blank – Standard</p> <ul style="list-style-type: none"> • DIN compatible <p>D – DMX512</p>
For an IGK		
QCI-D2	IGK	
This selection creates the part number: QCI-D2-IGK		

Contact Information

QuickSilver Controls, Inc.
 712 Arrow Grand Circle
 Covina, CA 91722
 (626) 384-4760 or (888) 660-3801
 (626) 384-4761 FAX
www.QuickSilverControls.com