

## NEMA 23 I-Grade Hybrid Servo Motors with Encoders



I-Grade NEMA 23 Hybrid Servo Motors



IP-65 Shaft Seal  
available separately.



IP-65 I-Grade NEMA 23 Hybrid Servo Motors

Note: Motor specifications (including torque curves) are only true when the motors are used in conjunction with QuickSilver’s SilverLode™ Controller/Drivers (i.e. SilverNugget™, SilverSterling™, and SilverDust™). See the controller datasheets for more details.

## General Motor Specifications

Specifications	23C-1	23C-3	23C-6	23C-8	23L-1C	23CK-3	23K-3C	23L-3C	23H-5C	23H-5
Maximum Speed (RPM)	4000	3600	2500	1000	4000	3000	2000	4000	4000	4000
48v Optimal Speed (RPM)	2500	1000	600	500	2500	600	600	1600	1000	1000
Torque (oz-in / Nm) at Optimal Speed	45 0.31	90 0.65	205 1.44	225 1.59	28.5 0.203	130 0.92	130 0.92	74 0.52	150 1.05	120 0.85
Continuous Stall Torque oz-in / Nm	75 0.53	170 1.20	300 2.11	380 2.68	44 0.306	145 1.00	145 1.00	95 0.67	240 1.69	190 1.34
Peak Power (Mech. Watts)	84	90	90	84	74	60	58	89	115	95
Rotor Inertia oz-in <sup>2</sup> / Kg-m <sup>2</sup>	0.82 1.5E-5	1.53 2.8E-5	3.28 6.0E-5	4.37 8.0E-5	0.82 1.4E-5	1.50 2.7E-5	1.50 2.7E-5	1.50 2.7E-5	2.1 4.0E-5	2.3 4.2E-5
Weight pounds / Kg	1.35 0.61	1.82 .82	2.97 1.35	3.41 1.55	1.40 0.65	1.70 0.77	1.70 0.77	1.70 0.77	2.6 1.20	2.6 1.20
Maximum Driver Input Current (Amps - DC)	4.0	4.0	4.0	4.5	4.0	3.2	3.0	3.5	4.2	4.0
Maximum Radial Force lbs / Newtons 0.79"/ 20mm from mounting face	16 71	16 71	16 71	16 71	16 71	16 71	16 71	16 71	16 71	N/A
Maximum Axial Force lbs / Newtons	4 17	4 17	4 17	4 17	4 17	4 17	4 17	4 17	4 17	N/A
Notes	Round shaft	Round shaft	Round shaft	Round shaft	Round shaft	Round shaft	Round shaft	Round Shaft	Round shaft	Round shaft

Notes for obsolete motor types:

A23L-1: replace with A23L-1C for plug and play. Note: A23L-1C has a round shaft.

A23K-3, A23H-3: replace with A23CK-3 for improved power and performance, or for plug and play replace with A23K-3C. Note: A23K-3C has a round shaft.

A23-5: replace with A23C-6 for improved power and performance.

A23H-5: replace with A23H-5C for improved power and performance.

## Torque Curves

48V Max is the torque of the motor when the Torque Limits (TQL) command is set to “Max” (see SilverLode Command Reference for details on the TQL command). Operating the motor

in this mode requires proper heat sinking on the Controller/Driver and motor to prevent overheating. "Max" is only recommended for approximately 1-3 minutes at a time.

All other torque curves represent motor torque at the specified voltage when the TQL command is set to "100%". These curves represent torque up to 100% duty cycle depending on ambient temperature, heat sinking and air flow.

Important: There is a slight reduction in available torque if the shaft seal (sold separately) is used due to the drag of the quad seal around the shaft.  
"Optimal Speed" point provides the maximum available power at "100%" torque setting, which is usually the maximum efficiency point as well. If these two points differ, the "Optimal speed" is approximately the average of the two speeds.

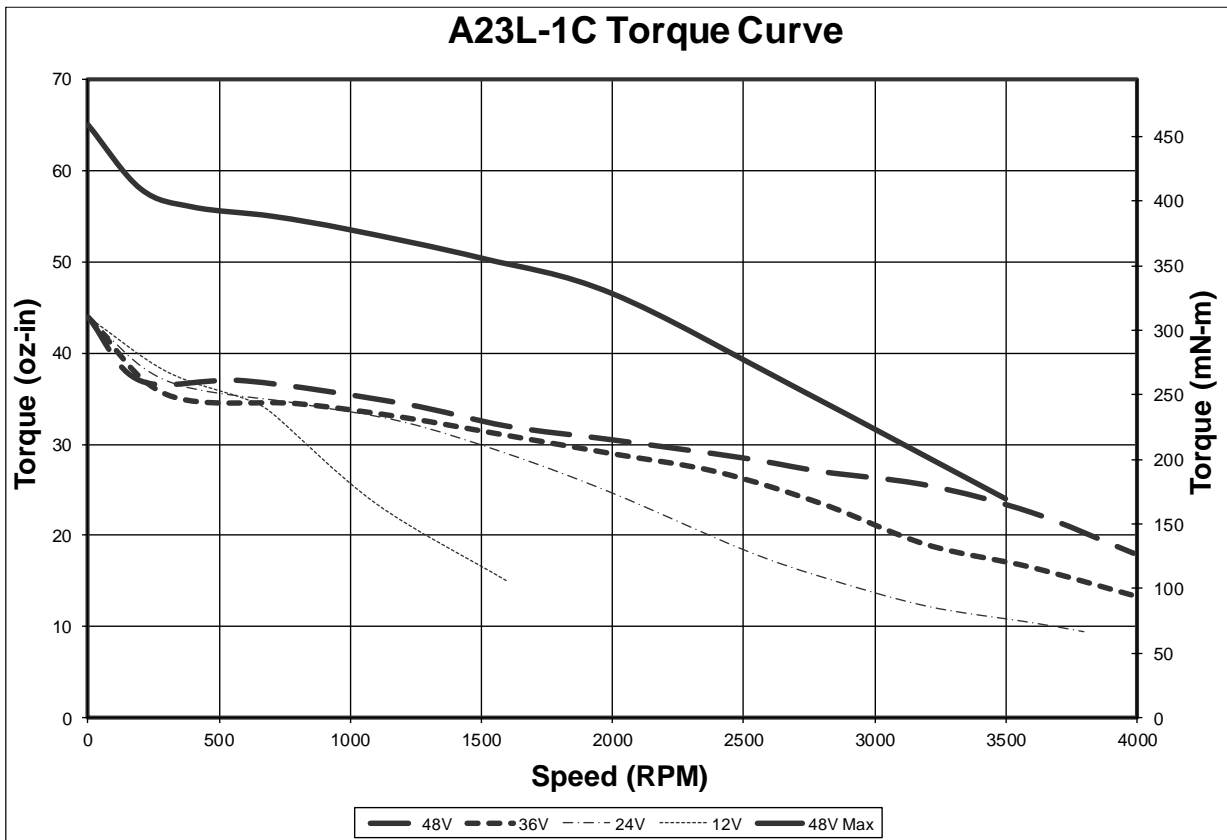

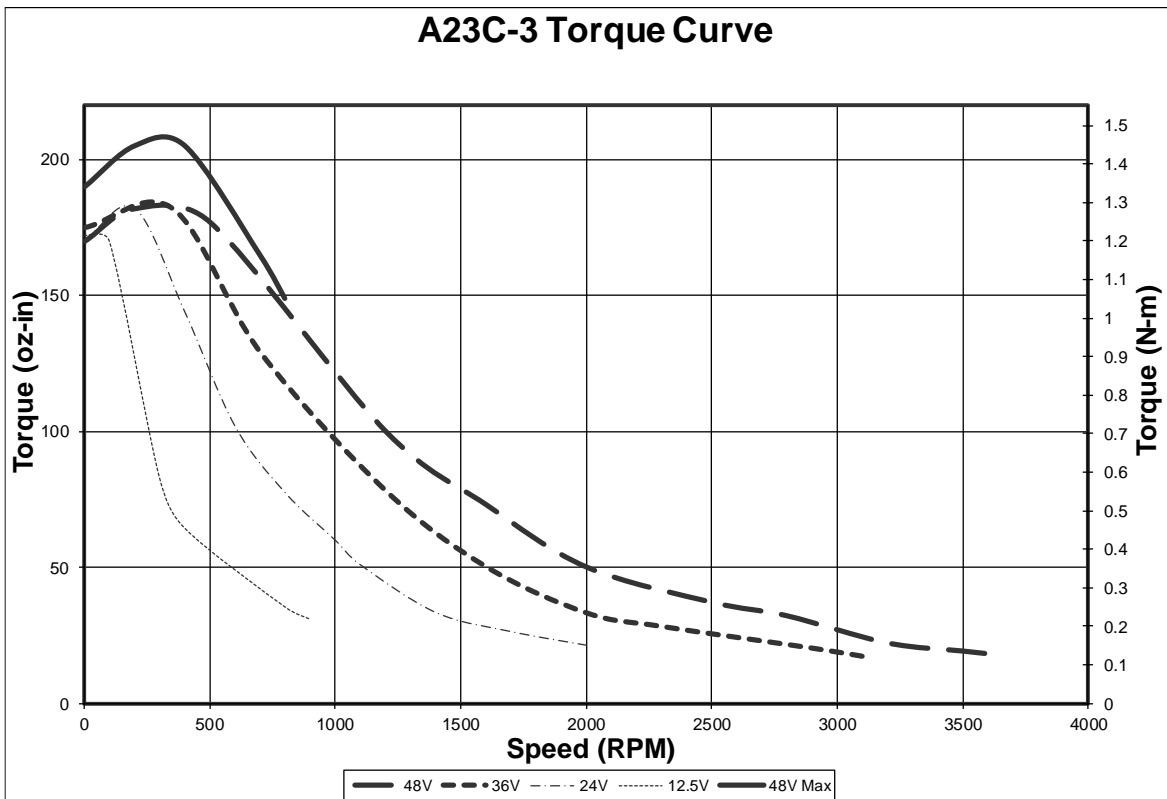
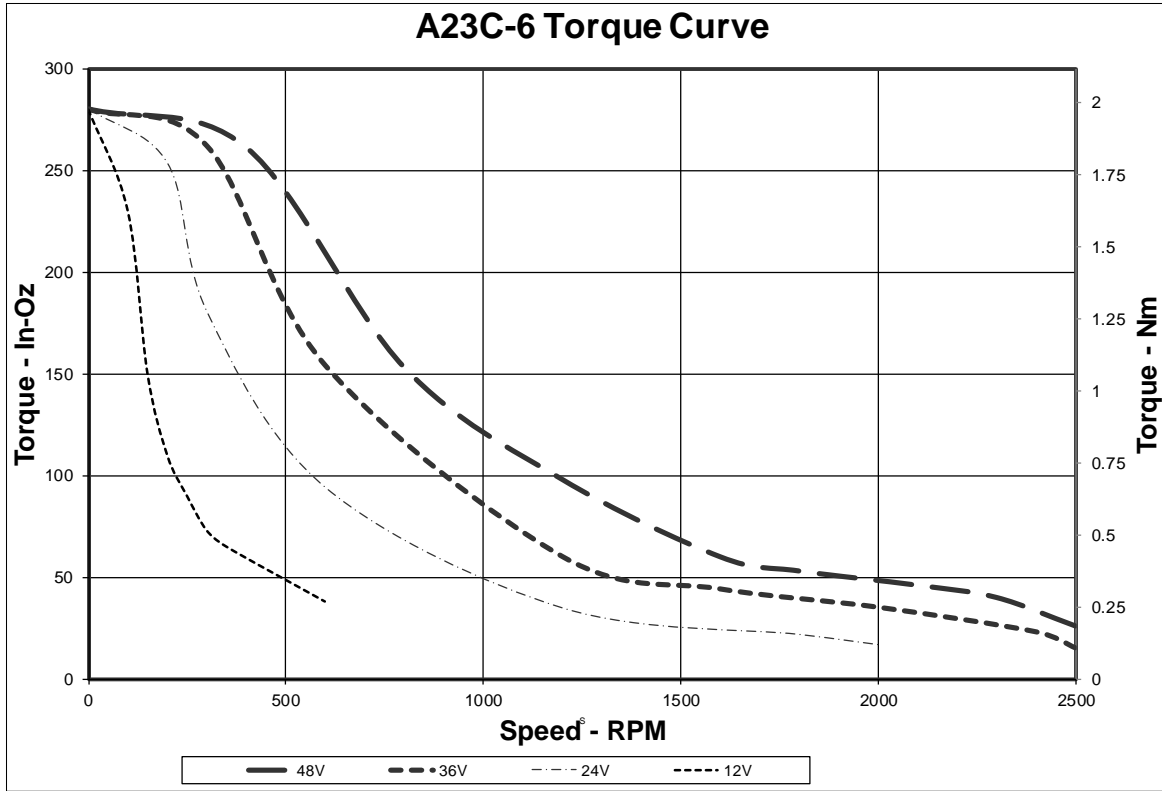

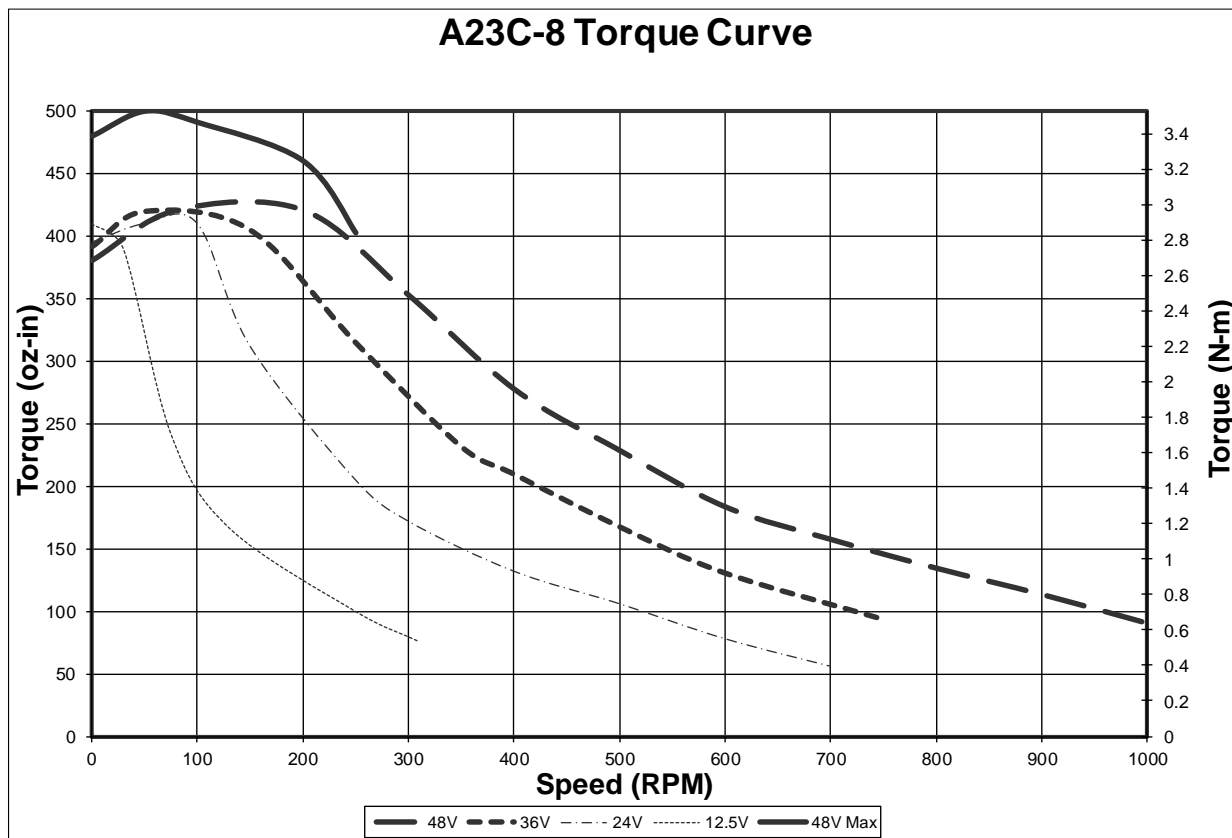
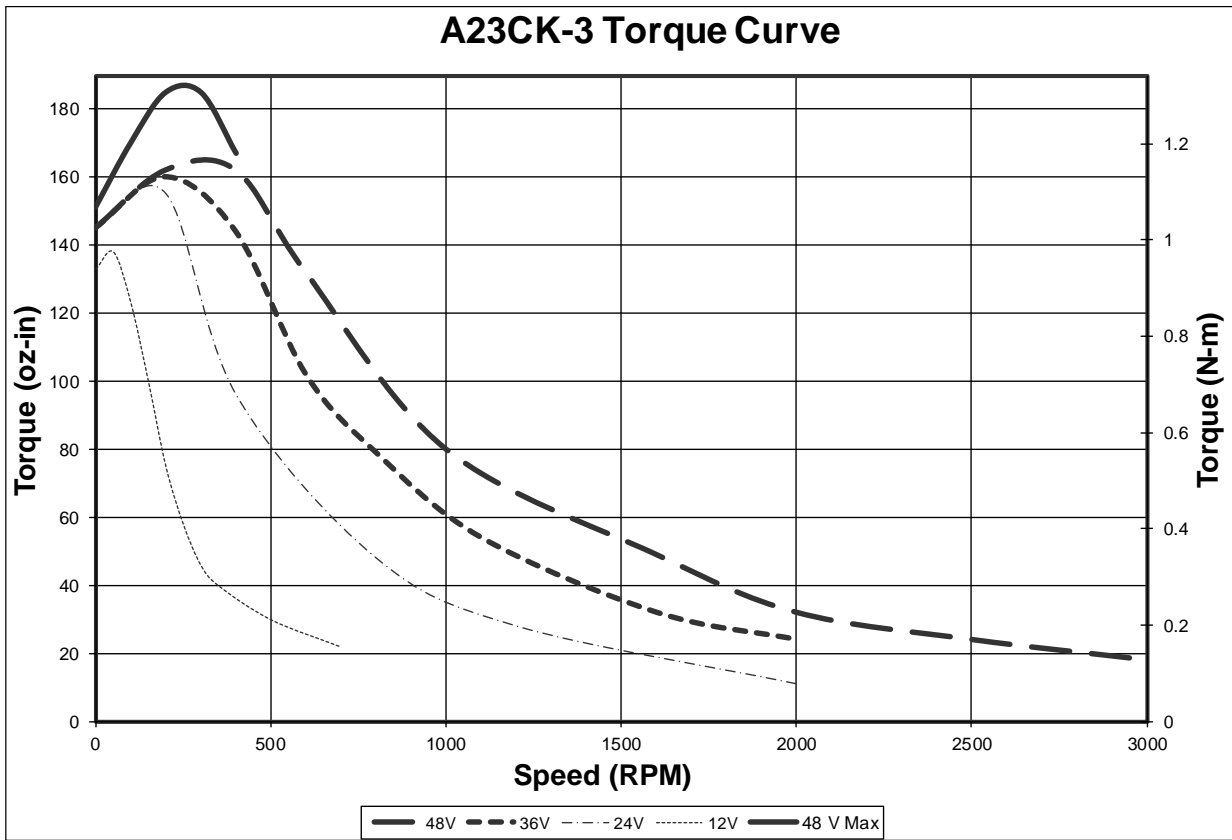

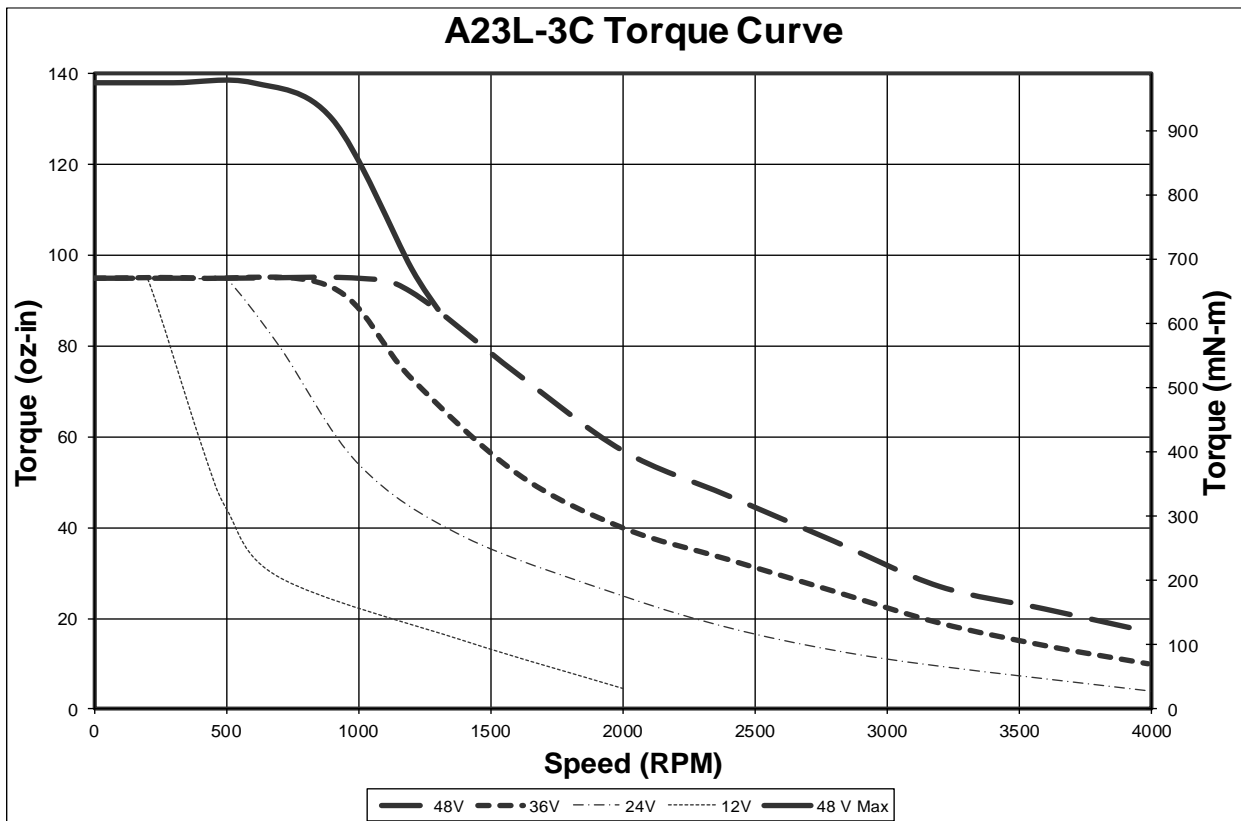
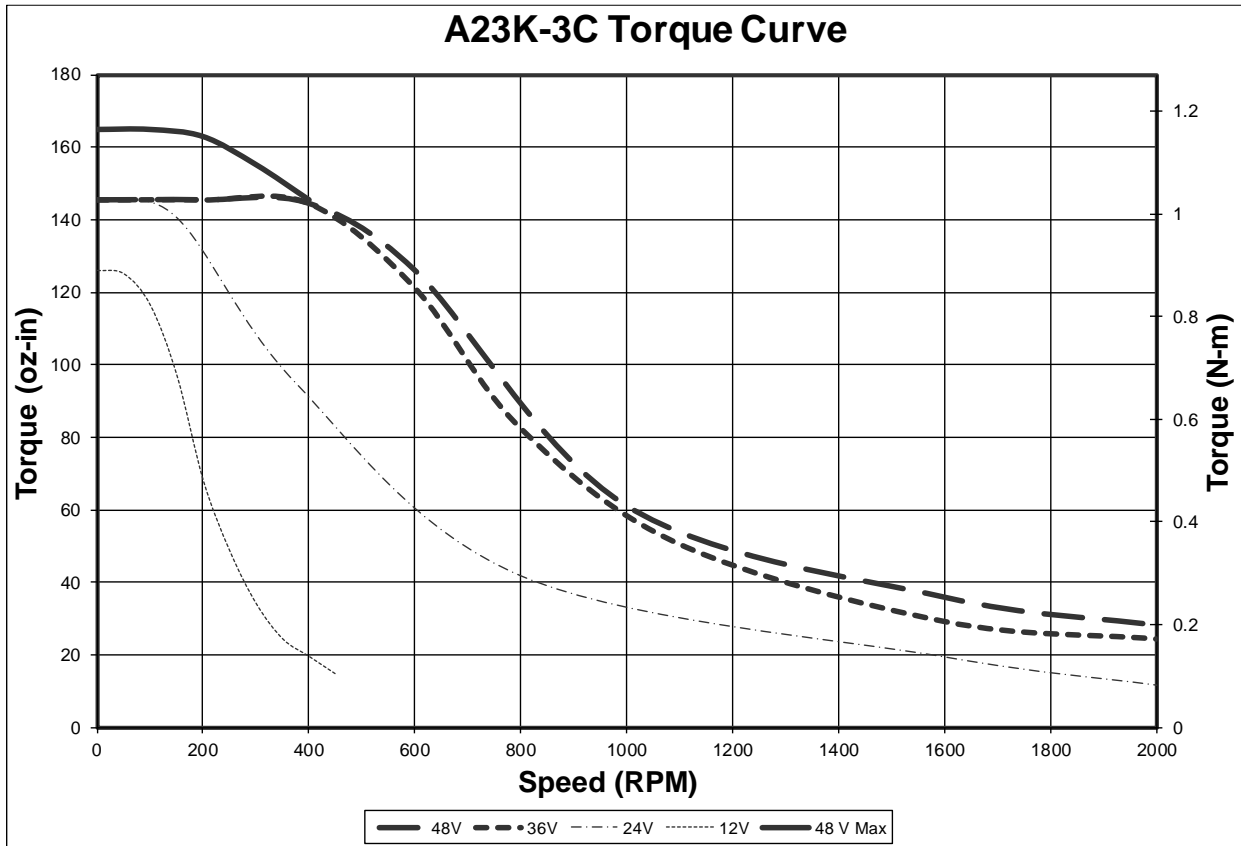

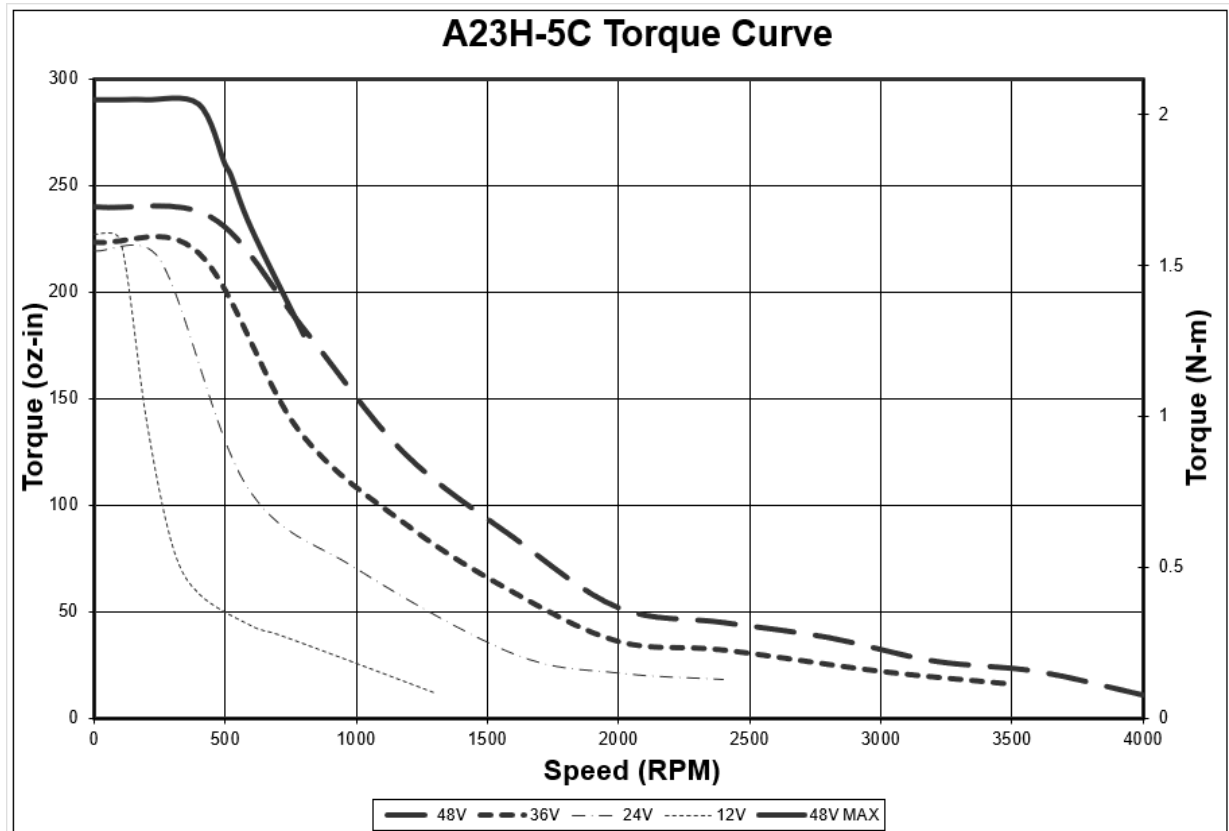
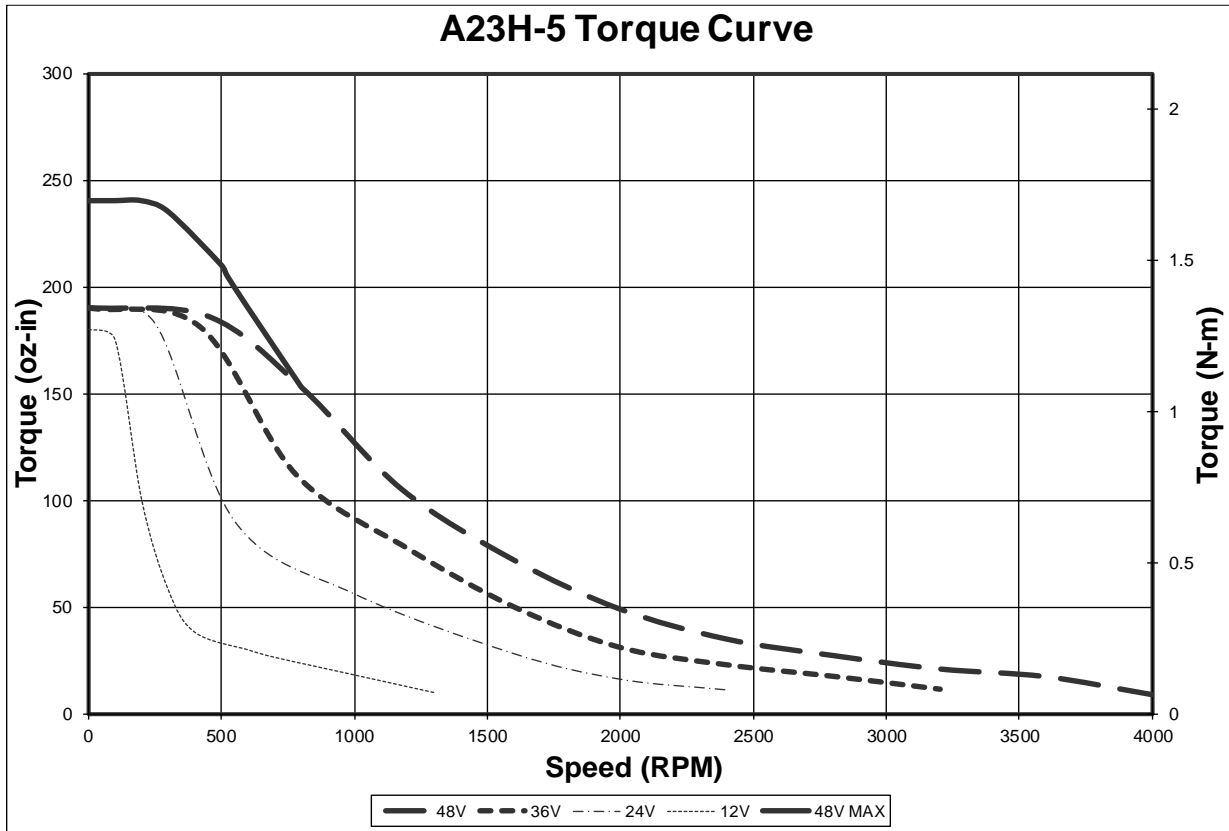

## **Electrical Specifications**

### **Encoder Interface**

Encoder Count Per Revolution: 8000

Index Pulse: 49 - SilverLode controller/drivers internally translate to a single index pulse.

### **Motor Memory**

I-Grade motors come from the factory with a memory chip containing an encoder and motor information. This information is automatically uploaded by the SilverDust IG/IGB controller/driver to simplify the initialization process.

### **Temperature Sensor**

All QCI IP65 motors contain a sensor to read motor temperature. This sensor automatically reads in the background when controlled by a SilverDust IG/IGB controller/driver.

Temperature can be read from a dedicated register and/or used to halt the servo in the case of an over temperature condition.



## Connector Data

### Standard

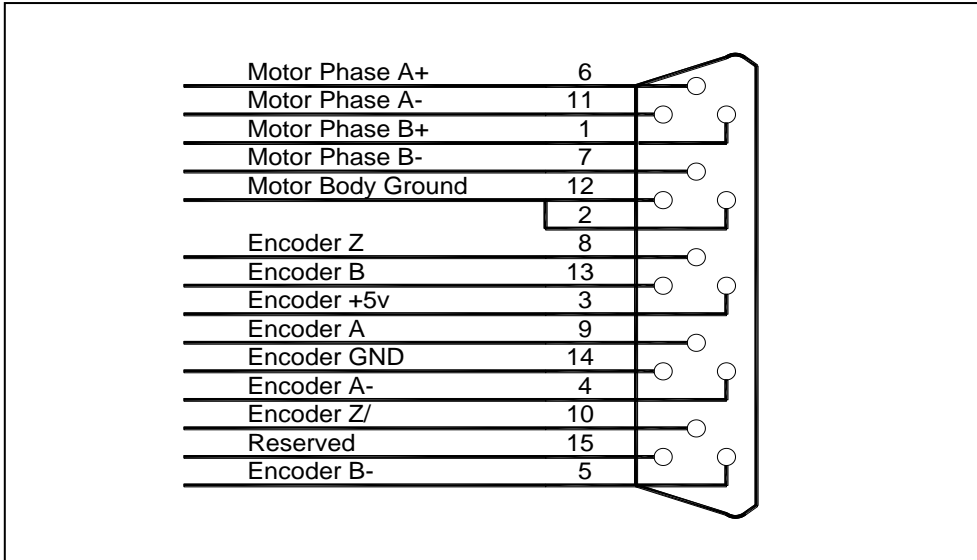

### -6T Option

Pin	Signals
A	Motor A -
C	+5V
E	Memory
G	Motor B+
J	Motor B -
L	Motor A+
M	Z+
N	Z -
O	A+
P	B -
R	B+
S	GND
T	A-
U	Motor GND

EXPOSED FRONT VIEW OF MOTOR CONNECTOR

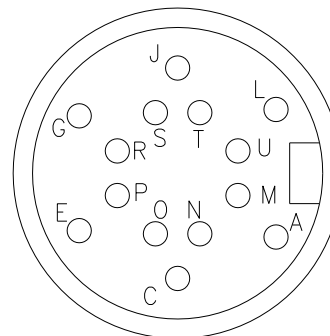

### Mechanical Specifications

Standard (Note: 3d models are available on our webpage)

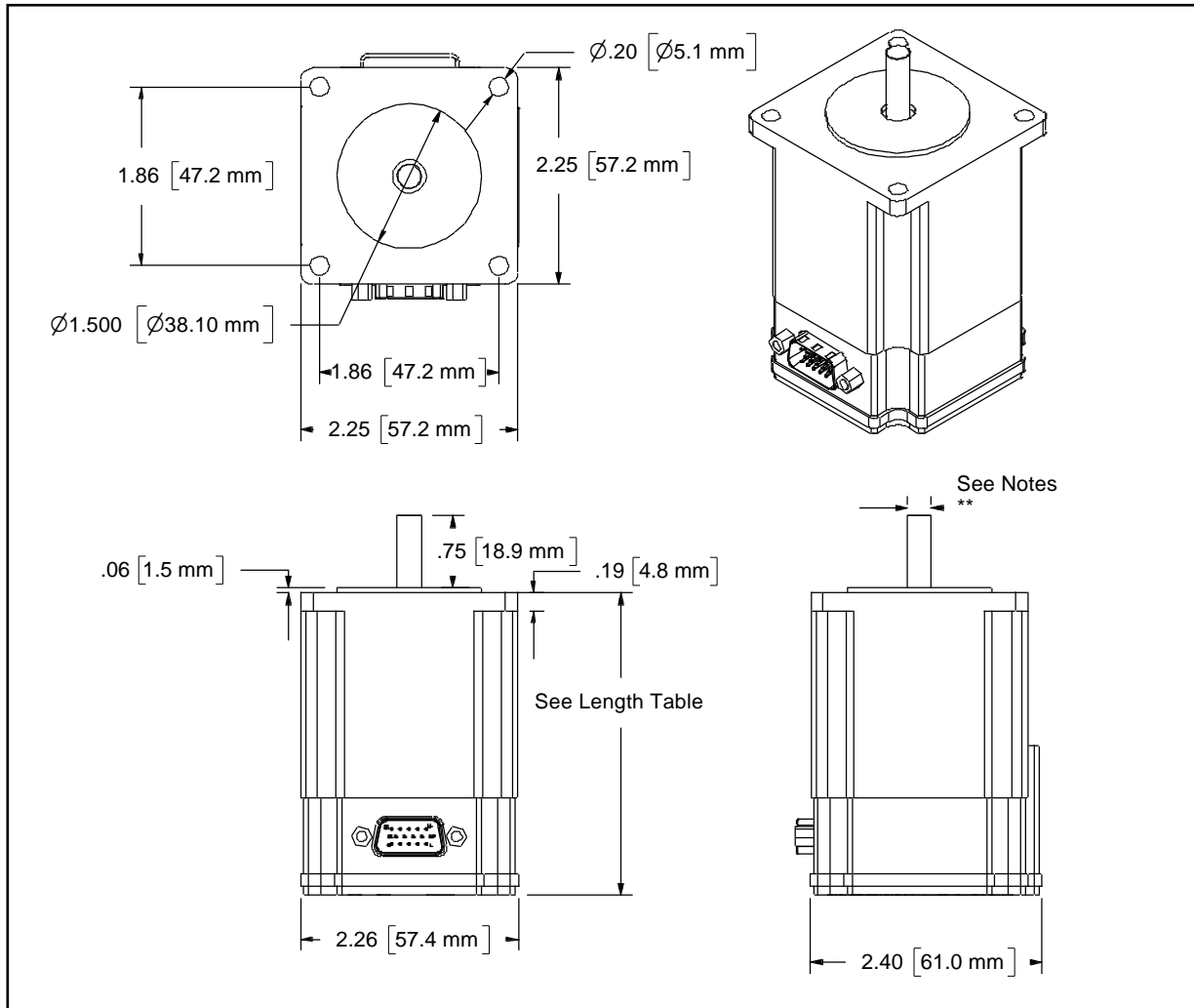

Motor Series	Length	Shaft diameter	Notes **
23L-1C, 23C-1	2.7 [68 mm]	.250 [6.35 mm]	
23CK-3, 23K-3C, 23L-3C, 23C-3	3.25 [81 mm]	.250 [6.35 mm]	
23H-5, 23H-5C	4 [101 mm]	.250 [6.35 mm]	
23C-6	4.3 [109 mm]	.315 [8mm]	
23C-8	5.5 [139 mm]	.315 [8mm]	

**-6T Option** (Note: 3d models are available on our webpage)

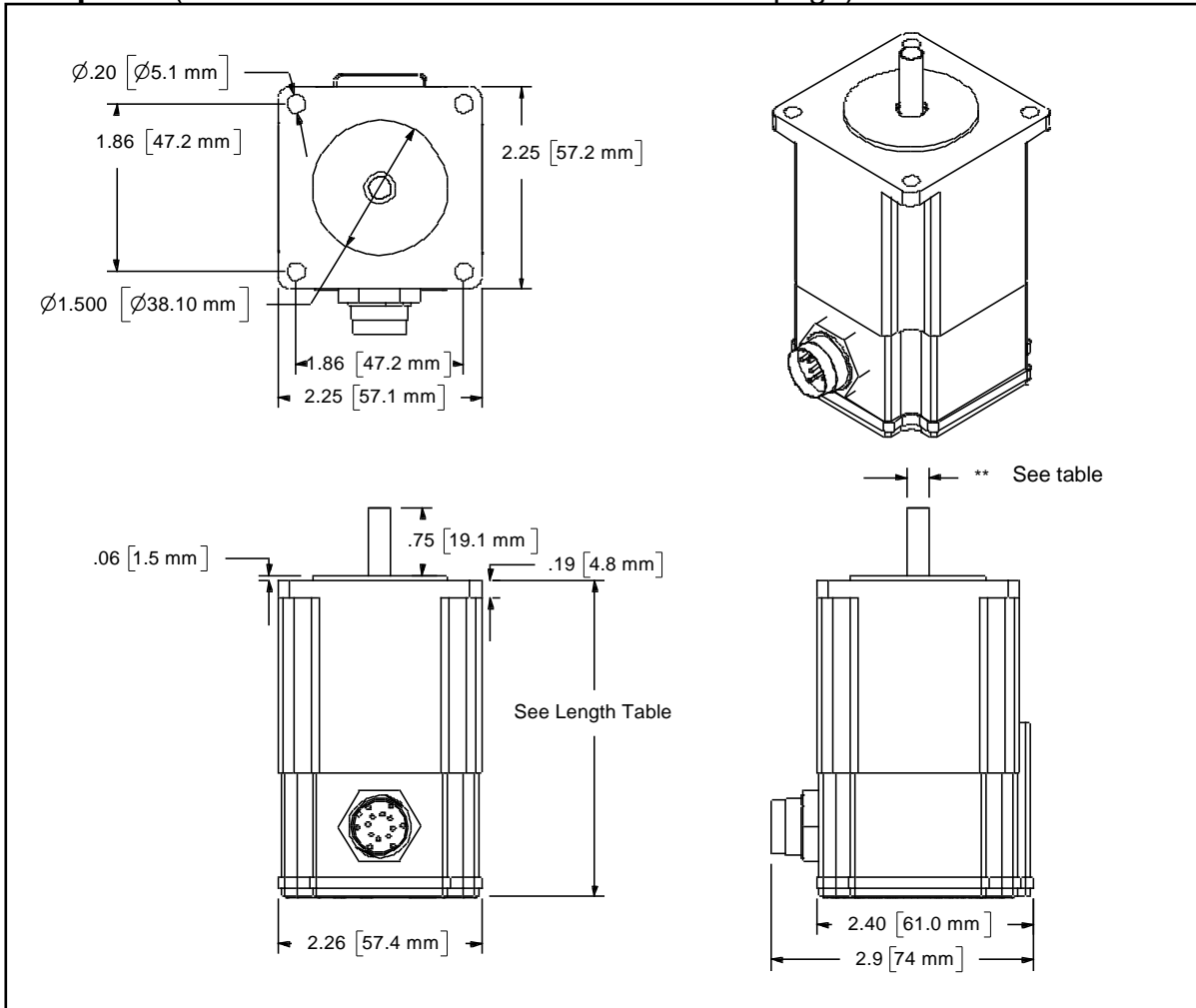

Motor Series	Length	Shaft diameter	Notes **
23L-1C, 23C-1	3.1 [78 mm]	.250 [6.35 mm]	
23CK-3, 23K-3C, 23L-3C, 23C-3	3.6 [91 mm]	.250 [6.35 mm]	
23H-5, 23H-5C	4.4 [111 mm]	.250 [6.35 mm]	
23C-6	4.7 [119 mm]	.315 [8mm]	
23C-8	5.9 [149 mm]	.315 [8mm]	

**⚠Note:** The motor construction uses a wave spring to compensate for mechanical tolerances and thermal expansion in the axial shaft direction. It is important to not push the shaft into the motor in operation or when mounting gears or pulleys as this may damage the encoder disk.

## Environmental Specifications

### Operational Temperature

-10 C to +80 C

### Storage Temperature

-40 C to +85 C

### Humidity

Continuous specification is 95% RH non-condensing.

### Shock

Limitation is approximately 50g/11ms.

### IP Rating - Standard

IP50

### IP Rating – 6T Option

IP65 is achieved if both a shaft seal and IP65 Motor Interface Cable (QCI-C-D15P-T14S-nn) are used.

NOTE: The IP65 rating is for applications with occasional wash downs. It is not meant for continuous wet applications or high-pressure wash downs. See IP65 spec for more details (CEI IEC 529).

## Recommended Components

The motors will work with any of the following controller/drivers. See the indicated datasheets for details:

- SilverDust D2 IGB (QCI-DS003)
- SilverNugget QCI-N2-IX (QCI-DS031)
- SilverDust D2 IG8 (QCI-DS018)
- SilverDust D2 IG (QCI-DS019)
- SilverDust D2 IGF (QCI-DS021)
- SilverSterling S2-IG (QCI-DS026)

### Motor Interface Cable (QCI-C-D15P-D15S-nn)

This cable goes between the motor and the QuickSilver Controller/Driver (SilverNugget). Replace the last two digits “nn” with length of cable in feet (i.e. – 10 for 10 feet).

### Shaft Seal (QCI-23M-65)

The shaft seal (sold separately) is required for an IP65 rating on the shaft end of the motor. The shaft seal consists of an o-ring seal for the motor’s pilot and a quad ring seal for the shaft. The shaft seal needs periodical inspections, lubrication, and replacement if worn out.

### IP65 Motor Interface Cable (QCI-C-D15P-T14S-nn)

This cable goes between the motor and the SilverLode™ Controller/Driver (SilverDust D2 or SilverNugget N2). Replace the last two digits “nn” with length of cable in feet (i.e. –10 for 10 feet).

### SilverLode Manuals and QuickControl Software

The SilverLode User Manual, SilverLode Command Reference and QuickControl Software are also available on our website. We recommend first time users read chapter 1 of the User Manual before connecting power.

### Power Supply (i.e. RSP-320-48)

A 12-48V power supply producing the amps specified above (see General Motor Specifications) is required. QuickSilver recommends:

- RSP-320-48 (48V, 6.67A, 320W)

## Part Numbers

NEMA 23 I-Grade Motors/Encoders	
MOTOR TYPE/SIZE	MOTOR INTERFACE
<ul style="list-style-type: none"> <li>• A23C-1</li> <li>• A23C-3</li> <li>• A23C-6</li> <li>• A23C-8</li> <li>• A23L-1C</li> <li>• A23CK-3</li> <li>• A23K-3C</li> <li>• A23L-3C</li> <li>• A23H-5C</li> <li>• <b>A23H-5</b></li> </ul>	<p><b>Blank</b> – Standard</p> <ul style="list-style-type: none"> <li>• DB15HD Motor Interface Connector</li> </ul> <p><b>6T</b> – IP65</p> <ul style="list-style-type: none"> <li>• 14 Pin Round Connector</li> <li>• Shaft seal required for full IP65 rating.                             <ul style="list-style-type: none"> <li>○ QCI-23M-65</li> </ul> </li> <li>• Extra coating on motor exterior.</li> </ul>
<p>To create a part number, choose one from each column above. For example: 23C-3</p>	
<b>QCI-A23C-3</b>	
<p>This selection creates the part number: <b>QCI-A23C-3</b></p>	

### Standard Stocked Items

QCI-A23C-1	QCI-A23L-1C
QCI-A23C-3	QCI-A23CK-3
QCI-A23C-6	QCI-A23K-3C
QCI-A23C-8	QCI-23L-3C
	QCI-23H-5C

Special Orders: all 6T options

## Contact Information

QuickSilver Controls, Inc.  
 990 N Amelia Ave  
 San Dimas, CA 91773  
 909-599-6291  
 909-599-6289 FAX  
[www.QuickSilverControls.com](http://www.QuickSilverControls.com)