

Eason HMI

Eason Contact Information

Eason Technology, Inc.

Phone: 707-433-2854

Tech Support: 707-433-2854 Ext: 36

Fax: 707-433-3706

Website: www.eason.com

Support office email: info@eason.com

Recommended Parts List

SilverNugget N2 I-Grade (QCI-N2-E3-04-EE)

Motor/Encoder (QCI-A23-3-A-01)

Communication Cable (QCI-C-D9M9F-6)

DB15HD Interface cable (QCI- EC-SMI-4)

DB15HD Motor I/F cable (QCI-C-D15P-D15S-10)

Eason Intelligent Operator Interface (Model 2300)

Software Requirements

QCI's "QuickControl" ver. 4.2

Eason's "WinBuild 2000" ver. 4.12

Hardware Setup

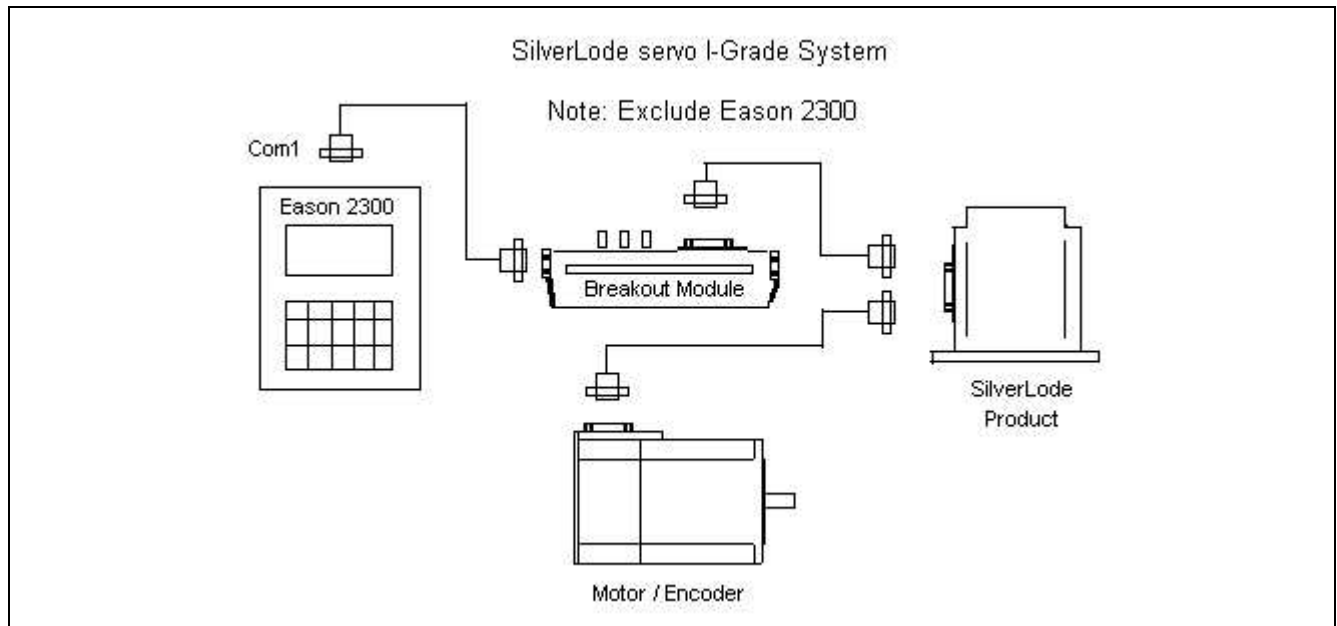

Serial Communication Settings

SilverLode

Hardware Interface: RS-232 (default)

Baud Rate: 57600 (default)

Data Bits: 8

Stop Bits: 1.5 or 2

Parity: None

Protocol: "8-Bit ASCII" (default)

See SilverLode Multi-Function Interface (SMI) Port definitions on SilverLode controller for access to communication lines.

Eason

(settings specified in Example program):

COM: COM 1 or COM 2

(The COM connected to Breakout Module)

Baud Rate: 57600

Multi-Drop: 0

Parity: "N"

Data Bits: 8

Stop Bits: 2

Hardware Handshaking: 0

Software Handshaking: 0

Timeout: 250

Strip Incoming Linefeeds: 1

Strip Outgoing Linefeeds: 1

Strip Echo: 0

Binary Mode: 0

Inter-Char Send Delay: 0

Optional RS 485 Connection

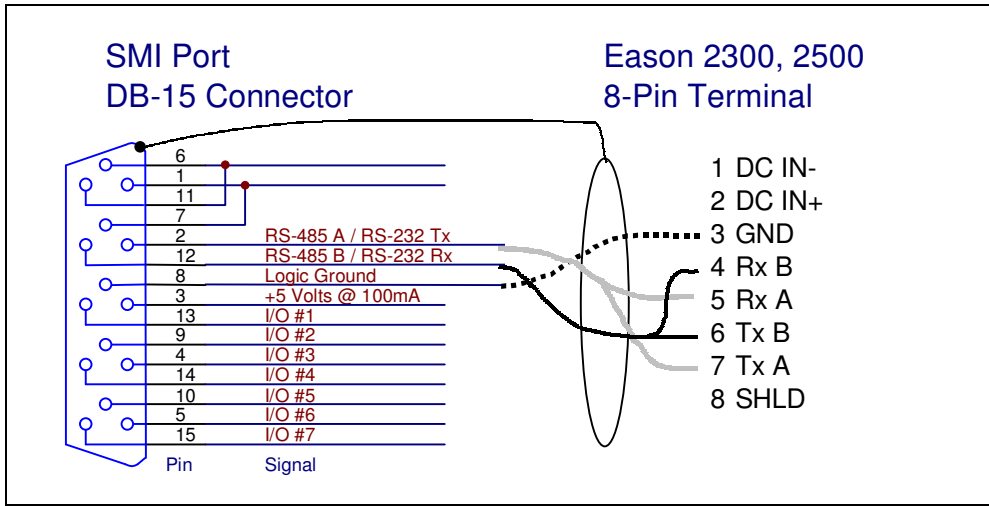

Note: Be sure to re-initialize QuickControl with the proper com interface (RS 485), because the default, from the factory, is RS 232.

Commands Supported by Eason/SilverLode Servo Driver

Because the Eason uses a standard serial driver, the Eason OIT can implement ALL SilverLode servo host commands, including any future commands.

Sending a Command to the Servo

1. Click the "Button Tool" in the program menu.
2. Right-click in the screen to insert the button.
3. Double-click on the newly inserted button.
4. Select the Psuedocodes tab.
5. Click the "On Press..." option.
6. In the Basic Psuedocode Editor, Select "COM: INIT" under New Psuedocode and click the "Add" button.
7. Enter the correct parameters in the "Com Init" window that pops-up (See the Serial Communications Settings section of this document for the recommended settings).
8. Click the "OK" option and a new text line, specifying the com port settings, should have been added to the Code for Current Object portion of the Basic Psuedocode Editor window.
9. Now, from the keyboard, enter the following in the next line after the Com Init command:

```
COM: PUT COM 1 VALUE "@16 135 80000 10000 53687100 0 0"
-This command tells the servo to move a relative distance of 20 revolutions
```

(The "COM: PUT COM 1 VALUE" tells the Eason to send the following ASCII string out the specified COM port. Refer to the Command Reference for the correct format of commands.)

10. "Compile, download, reboot!" the Eason, and the Eason should now display the button on the screen.

11. Press the button on the Eason touchscreen and verify that the servo does respond by moving 20 revolutions.

Reading a Response From the Servo

1. In the main menu, select Setup; then select Tags.
2. In the PLC Contact and Tag Setup window, Click the “New Tag” option, and enter “REPLY” for a name and add the following parameters:

Source = Internal Volatile

Address = S

3. In the main menu, select Setup; then select Subroutines.
4. Now add a New Subroutine and name it “LISTEN”.
5. In the Code for Current Object section, select the “COM: GET COM port TAG tag” command under New Psuedocode.
6. In the pop-up window, enter the correct Com port number and select the Tag “REPLY\$”.
7. Once in the main programming window, select the Data Entry Tool icon.
8. Place the entry on the screen and double-click on the new entry.
9. Click the Data tab, and select the Tag “REPLY\$”.
10. Click the Entry/Display; then select Data Display.
11. Now, in the same Data Entry Properties window, under the Format String: section enter a letter “S” for every character that needs to be displayed. For example: “SSSS” would need to be entered to ensure that a response of “1234” would be properly displayed. (Refer to the Command Reference for a complete description of all responses.)
12. For every time that a response needs to be read, call the Subroutine “LISTEN”. In the included example Eason interface program, the Release option for each button included the following Psuedocode: “GOSUB LISTEN”. This called the subroutine each time to read the servo response into the Tag “REPLY\$”. Once this is done, the Data Entry bar in the Eason Screen displays the response.

Troubleshooting Tips

No Communication

Make sure both the Eason and the servo have been setup for the same communication parameters. See the “Serial Communication Settings” section of this document for recommended settings. Also, try just sending the ASCII character “@”. This character calls the servo’s attention. The Red LED on the back of the controller/driver should become noticeably brighter after the character was sent. If that is not the case, double-check the wiring.

Communication Between SilverLode and Eason is Sporadic

Check communication lines for EMF induced noise. Try a slower Baud Rate; especially if the communication lines are long. In addition, the servo has an Acknowledgement Delay setting. This setting specifies how long the servo should wait before sending a reply. The servo can send back a response within 120microseconds of receiving the end of a command. If the Eason is performing other operations, the COM port could end up chopping off the beginning of the response. In this case, increasing the Acknowledgement Delay should help alleviate the problem. Refer to the Command Reference for a more thorough explanation.